

EATON

Char-Lynn

Disc Valve Motor

**4000 Series
Geroler® Motors**

Std., Whl. and Brgl. **-004** Std. and Whl. **-006**

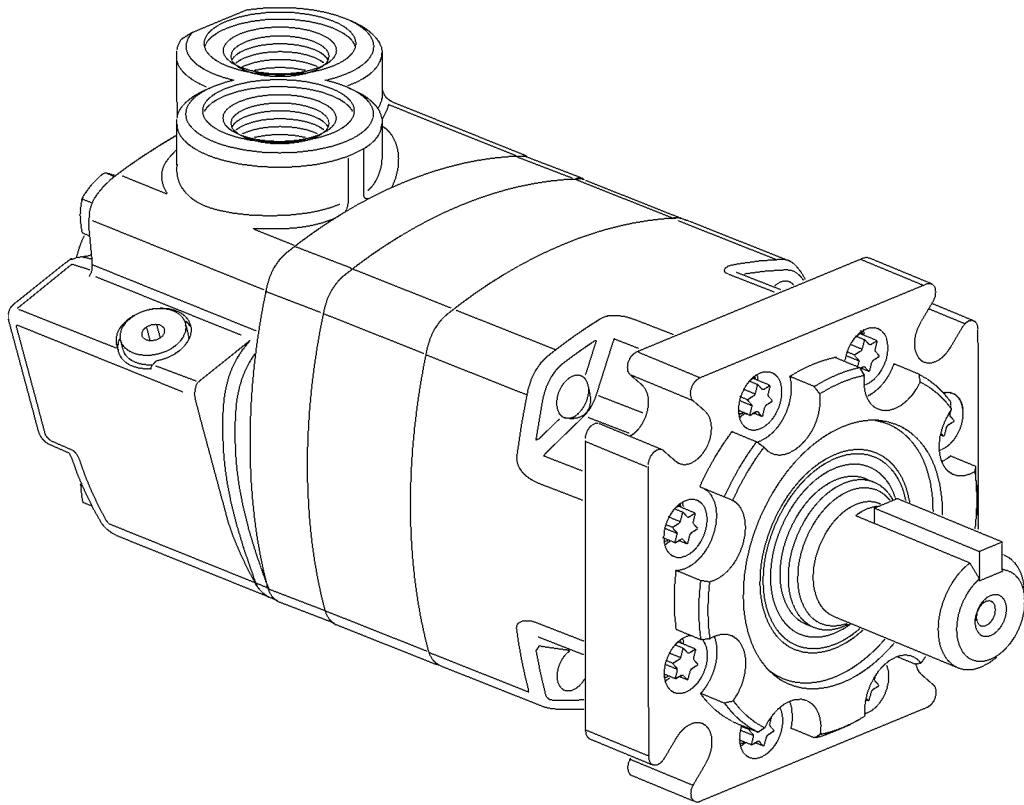

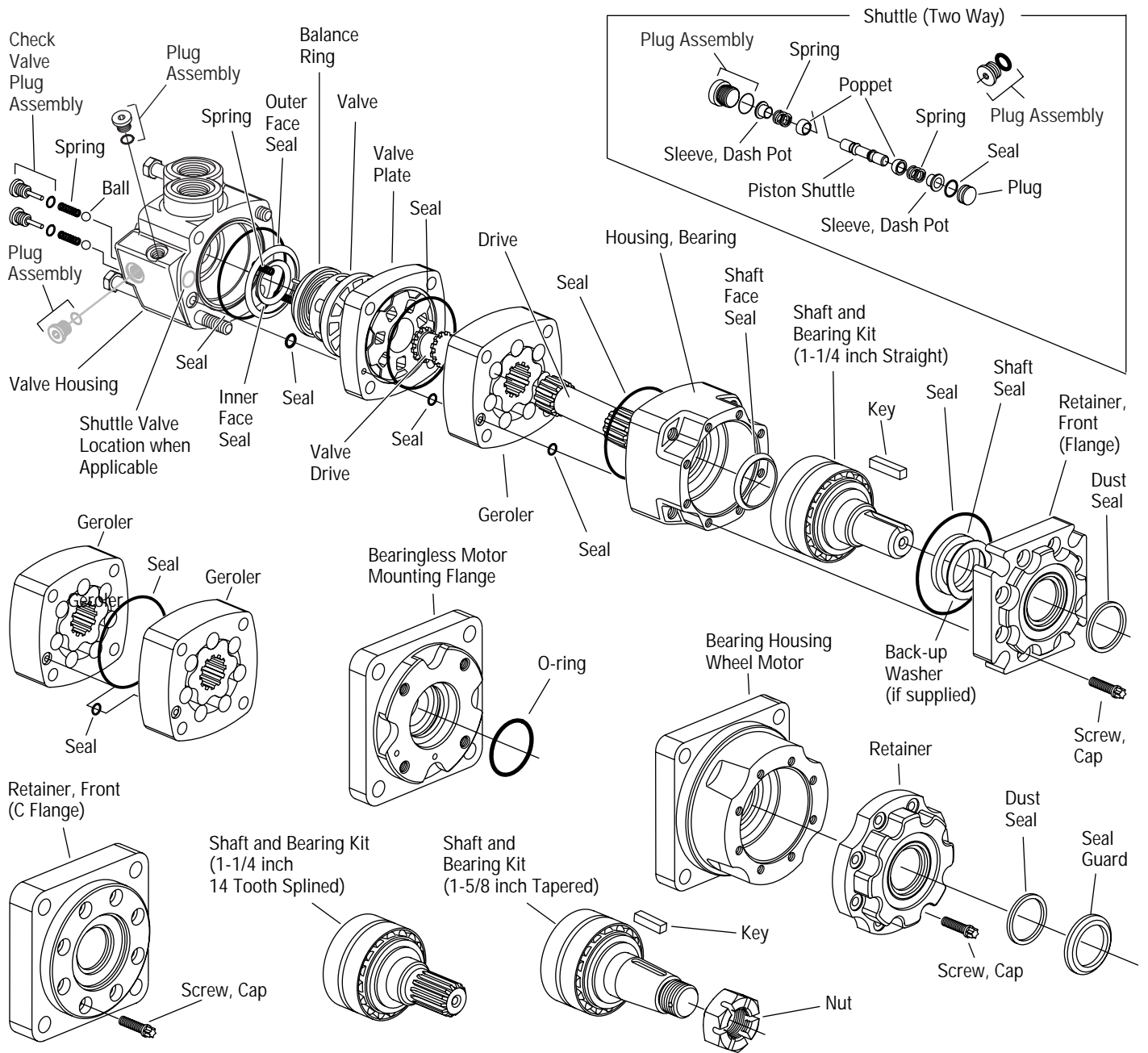

Tools

Wheel motor and bearingless motor repair information on page 9 and 10.
 Shuttle valve and seal guard repair information on page 10.
 Seal guard reference on page 10.

Tools required for disassembly and reassembly

- Torque wrench (68 Nm [600 lb-in] capacity)
- 300 to 400 mm [12 to 16 inch] breaker bar
- 3/4 inch and 1/2 inch sockets
- Small screwdriver (150 to 200 mm [6 to 8 inch] long, 6 mm [.25 inch] blade)
- 3/16 inch Hex Key
- Hydraulic press — 1335 N [300 lbf]
- Shaft face seal (-004) installation tool 600468
- Shaft face seal (-006) installation tool 600421-2
- * — Bullet (600463) for 1-1/4 inch diameter shafts
- Shaft seal installation tool (2 -1/4 inch socket)
- Torq wrench required for eight mounting flange screws (replacement screws or -006 design) No. E10

The following tools are not necessary for disassembly and reassembly but are extremely helpful

- Alignment studs (2), see dimensions below

* Available by special order, contact Eaton Corp., Hydraulics Division Service Dept.

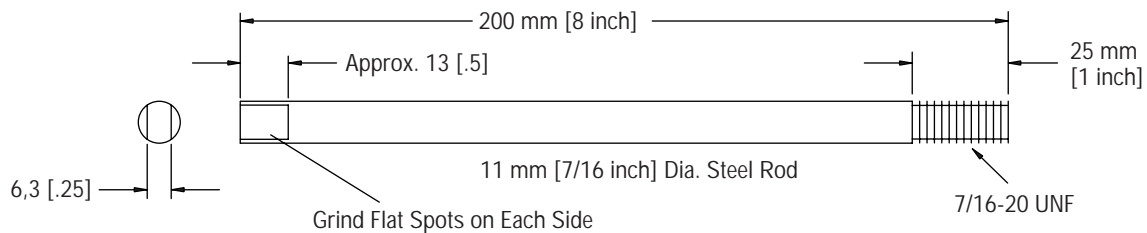

Disassembly

Cleanliness is extremely important when repairing a hydraulic motor. Work in a clean area. Before disconnecting the lines, clean port area of motor thoroughly. Use a wire brush to remove foreign material and debris from exterior joints of motor. Check shaft and keyway. Use 600 grit paper/cloth to remove all nicks, burrs, and sharp edges that might damage the shaft seals when installing retainer on shaft and bearing assembly. Before starting disassembly procedures, drain oil from inside of motor.

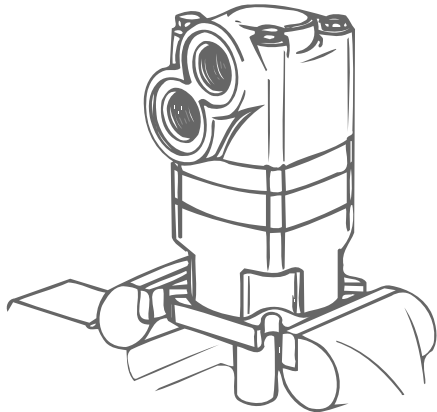

Figure 1

1 Place motor in a vise with output shaft down. Clamp across edge of mounting flange, not on housing (see Figure 1). Excessive clamping pressure will cause distortion. When clamping, use some protective device on vise, such as special soft jaws, pieces of hard rubber or board.

Although not all drawings show the motor in a vise, it is recommended that you keep the motor in the vise during disassembly. Follow the clamping procedures explained throughout the manual.

2 Remove 4 bolts from the valve housing.

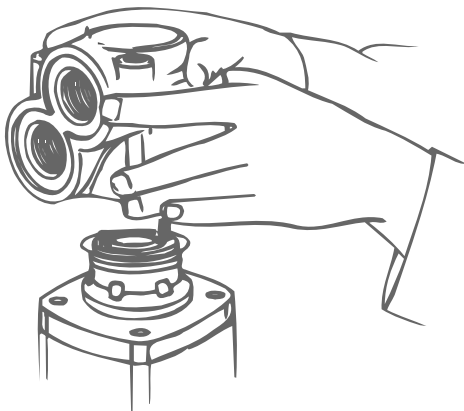

Figure 2

3 Lift valve housing straight up. If done carefully, the springs and balance ring subassembly will remain on valve for easy removal.

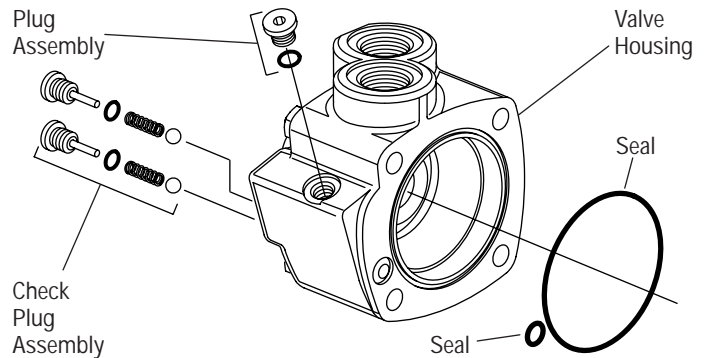

Figure 3

4 Carefully remove the following from the valve housing:

- 1 seal, 82,3 mm [3.24 inch] I.D.
- 1 seal, 8,9 mm [.35 inch] I.D.
- 2 check valve plug assemblies (plug, seal, spring, ball) 1 plug (case drain) with seal.

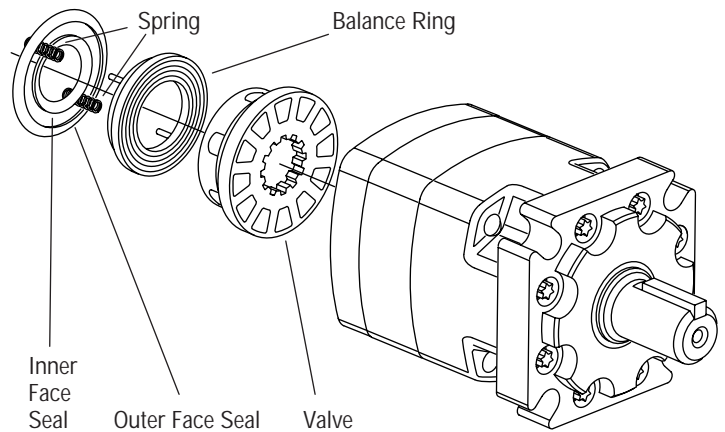

Figure 4

5 Remove 2 balance ring springs.

6 Remove balance ring subassembly.

7 Remove inner and outer face seals from the balance ring.

8 Lift off valve.

Disassembly

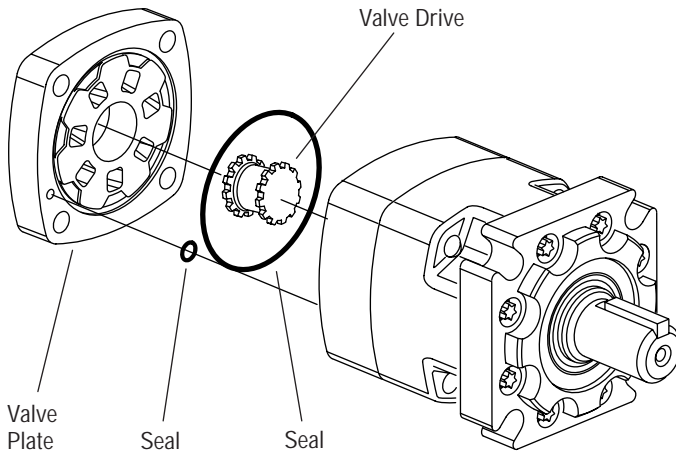

Figure 5

9 Remove valve plate.

10 Remove 88,6 mm [3.49 inch] I.D. seal from valve plate (see Figure 5).

11 Remove valve drive (see Figure 5).

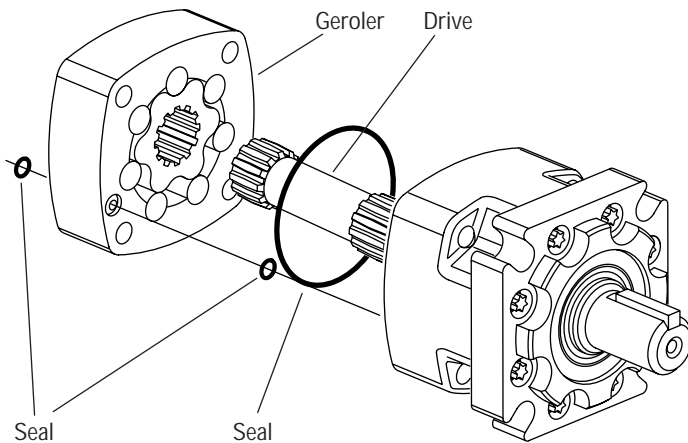

Figure 6

12 Remove Geroler. Retain rollers in outer Geroler ring if they are loose.

13 Remove 2 seals from Geroler, 1 seal on each side of Geroler.

14 Remove drive.

15 Remove 88,6 mm [3.49 inch] I.D. seal from bearing housing.

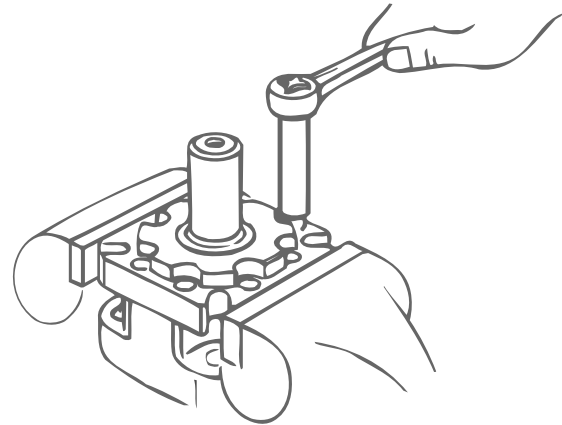

Figure 7

16 Use a stud remover or vise grips to remove studs (earlier models only). Clamp bearing housing in vise as shown in Figure 7. Loosen 8 screws. Remove screws, washers (discard washers, as they are not required for reassembly), and mounting flange (see Figure 8).

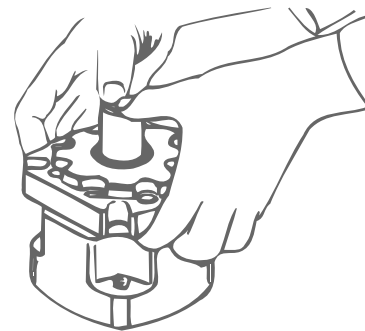

Figure 8

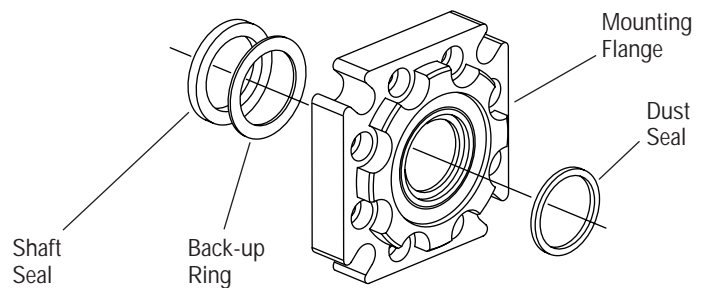

Figure 9

17 Remove shaft seal, back-up ring (if used) and dust seal from flange. Use a small screwdriver to remove dust seal. Do not damage bore of flange.

Disassembly

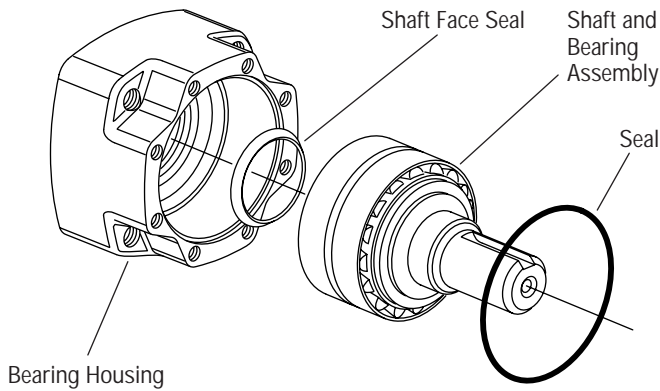

Figure 10

18 Remove shaft and bearing assembly. You may need a press to remove shaft and bearing assembly (see Figure 10).

19 Remove shaft face seal from bore of bearing housing (see Figure 10). Do not damage bore of bearing housing.

Note: Individual parts of the shaft and bearing assembly are not sold separately and must be replaced as a unit.

Reassembly

Check all mating surfaces. Replace any parts that have scratches or burrs that could cause leakage. Clean all metal parts in clean solvent. Blow dry with air. Do not wipe with cloth or paper towel because lint or other matter could get into the hydraulic system and cause damage. Do not use a coarse grit papers/cloth or try to file or grind motor parts. Check around the keyway and chamfered area of the shaft for burrs, nicks, or sharp edges that can damage the seals when reassembling the retainer.

Note: Lubricate all seals (prior to installation) with petroleum jelly such as Vaseline®. Use new seals when reassembling the motor.

Note: Shaft face seal installation tool is available by special order. Contact Eaton Corporation, Hydraulics Division (Service Department). 600468 (-004) 600421-2 (-006).

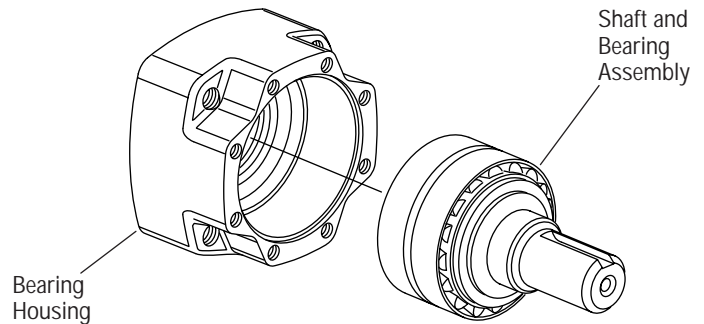

Figure 12

22 Install shaft and bearing assembly in bearing housing (see Figure 12). Do not damage seal in bore of housing. You may need a press to install shaft and bearing assembly.

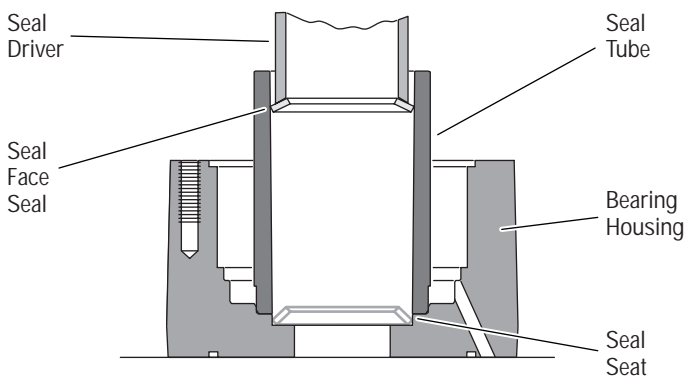

Figure 11

21 Place bearing housing on smooth flat surface with largest open end of housing up. Apply petroleum jelly to shaft face seal. Install seal in seal seat. Seat seal properly in groove (see Figure 11). A damaged or improperly installed shaft face seal could cause internal lubrication loss and subsequent parts wear.

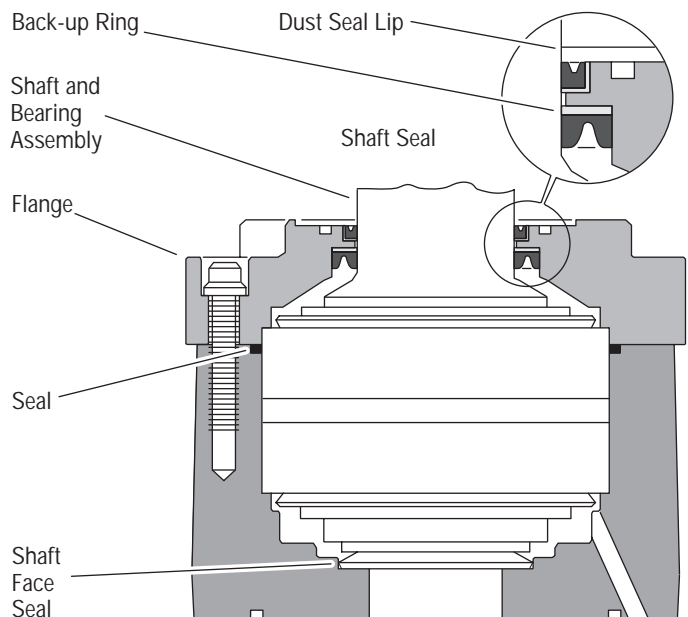

Figure 13

Reassembly

23 Apply petroleum jelly to 88,6 [3.49] ID seal. Install seal in seal groove of bearing housing (see Figure 13).

24 Use a small press, if available, to install dust seal in retainer. Metal side of dust seal must face toward flange, as shown in Figure 13. If a press is not available, use a plastic or rubber hammer to tap dust seal in place.

25 Install 92,1 [3.62] ID seal, back-up ring and shaft seal in retainer. Flat or smooth side of shaft seal must face toward retainer as shown in Figure 13. Apply petroleum jelly to inside diameter of shaft seal (after installing seal).

26 Before installing retainer, place a protective sleeve of bullet (see note below) over shaft. Grease inside diameter of dust and shaft seals. To prevent damage to seals, install retainer over shaft with a twisting motion. Do not cut or distort shaft seal. Damage to shaft seal will cause external leakage.

Note: Bullet 600463 for 1-1/4 inch diameter shafts available by special order through Eaton Hydraulics Division service department.

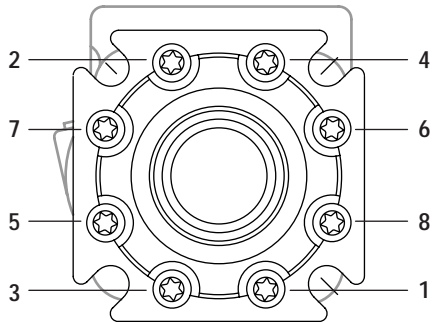

Figure 14

27 Lubricate threads of 8 screws with a film of light oil. Install and finger tighten screws. Clamp bearing housing in vise. Torque screws to 6 Nm [50 lb-in] in sequence (see Figure 14). Then final torque to 34 Nm [300 lb-in], in sequence. Install key (when used) in keyway of shaft.

Note: Full torque 34 Nm [300 lb-in] on one bolt at a time can damage bolt or retainer.

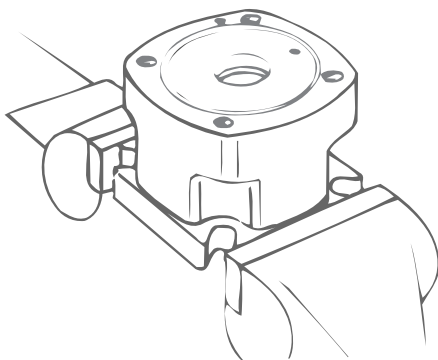

Figure 15

28 Reposition motor in vise with output shaft down. Clamp across edges of retainer as shown in Fig. 15.

29 Pour a small amount of light oil inside the output shaft.

30 Apply a light film of petroleum jelly on 88,6 mm [3.49 inch] I.D. seal. Install seal in bearing housing.

31 Install drive in output shaft (insert longer splined end of drive first), (see parts drawing on page 2).

32 To help in the reassembly procedure, it is recommended using two alignment studs (see special tools page 3) diagonally opposed in the four bolt holes of the bearing housing.

33 Apply petroleum jelly on 2 seals, 9,3 mm [.25 inch] I.D. Install seals (1 on each side of Geroler) in case drain grooves of Geroler.

Note: Installation at this point involves 3 steps in timing the motor. Timing determines the direction of rotation of the output shaft.

Timing parts include:

1. Geroler
2. Valve drive
3. Valve Plate
4. Valve

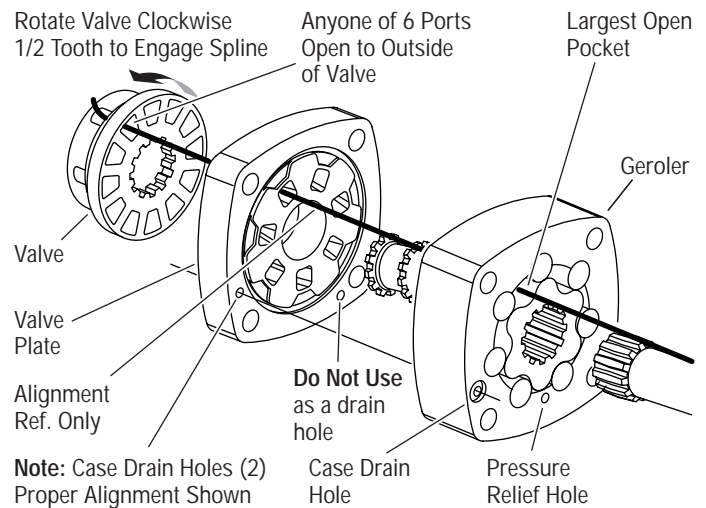

Figure 16 Timing Alignment

Timing Step No. 1 — Locate largest open pocket in Geroler. Then mark location of pocket on outside edge of Geroler (see Figure 16).

34 Align case drain hole and pressure relief hole in Geroler with case drain hole and pressure relief hole in bearing housing. Install Geroler on bearing housing (see Figure 16). Retain rollers in outer Geroler ring if they are loose.

35 Install valve drive in Geroler.

Reassembly

36 Apply a light film of petroleum jelly on 88,6 mm [3.49 inch] I.D. seal. Install seal in valve plate.

37 Align case drain hole in valve plate with case drain hole in Geroler. Install valve plate (seal side toward Geroler) on Geroler as shown in Figure 16.

Timing Step No. 2 — Locate slot opening in valve plate which is in line with largest open pocket of Geroler (see Figure 16).

38 Use the following procedure for installing the valve on the valve plate.

Timing Step No. 3 — Locate any one of the side openings of the valve that goes through to the face of the valve. **Line up this side opening in the valve with open slot of valve plate that is in line with largest open pocket of Geroler.** Rotate valve clockwise (1/2 spline tooth) to engage valve with the valve drive spline, alignment reference shown in Figure 17 (above). This procedure provides standard timing when pressurized as shown in Figure 17.

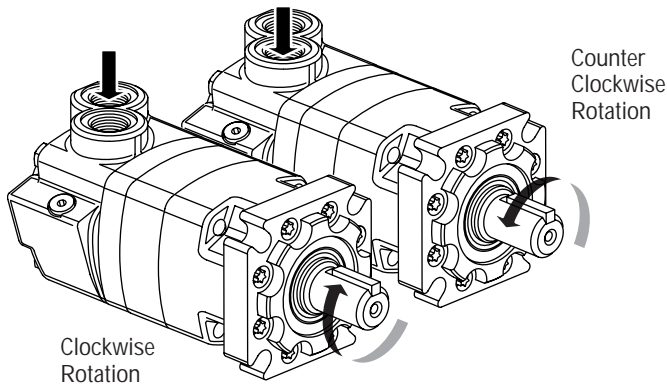

Figure 17

39 Apply clean grease on balance ring assembly springs. Install springs in 2 holes located inside bore face of valve housing (see Figure 18).

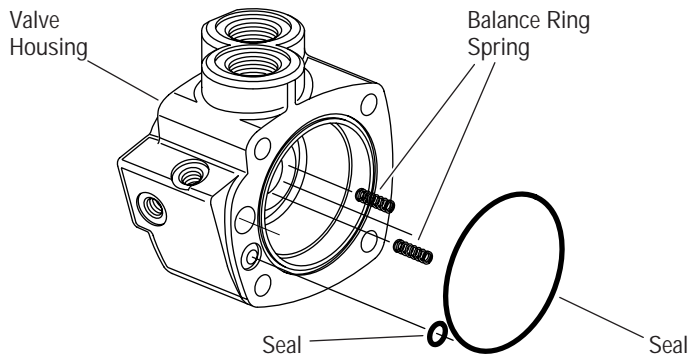

Figure 18

40 Apply a light film of petroleum jelly on 8,9 mm [.35 inch] I.D. seal. Install seal in case drain groove of valve housing.

41 Apply a light film of petroleum jelly on 82,3 mm [3.24 inch] I.D. seal. Install seal in outside seal groove of valve housing.

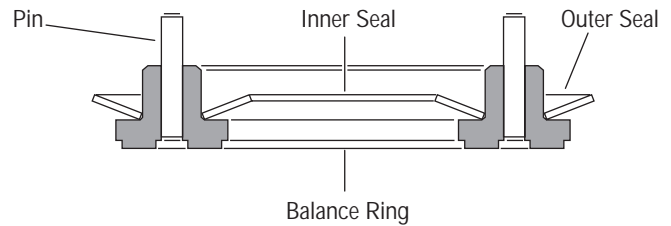

Figure 19

42 Apply petroleum jelly on inner and outer face seals. Install seals on balance ring as shown in Figure 19.

Important: Install face seals in the positions shown in Figure 19 or the motor will not operate properly. Do not force or bend these face seals. Any damage to these seals will affect the operation of the motor.

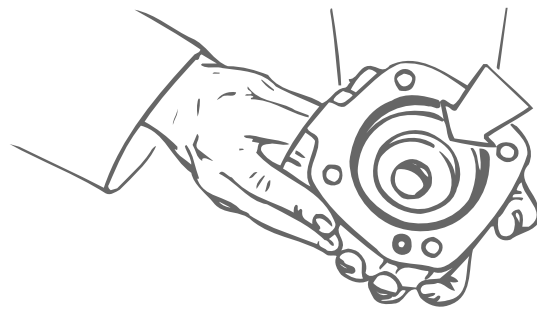

Figure 20

43 Align 2 pins of balance ring with 2 spring holes in valve housing as shown in Figure 20 . Install balance ring in valve housing.

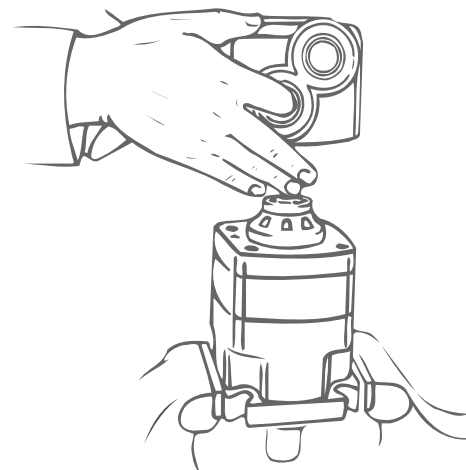

Figure 21

Reassembly

44 Insert your finger through port of housing. Apply pressure to side of balance ring assembly. Hold ring in position until valve housing is in place (see Figure 21). Align case drain hole in housing with case drain hole in valve plate. Install valve housing against valve plate (see Figure 22).

Note: After installing valve housing on valve plate, check between body parts of motor for unseated seals.

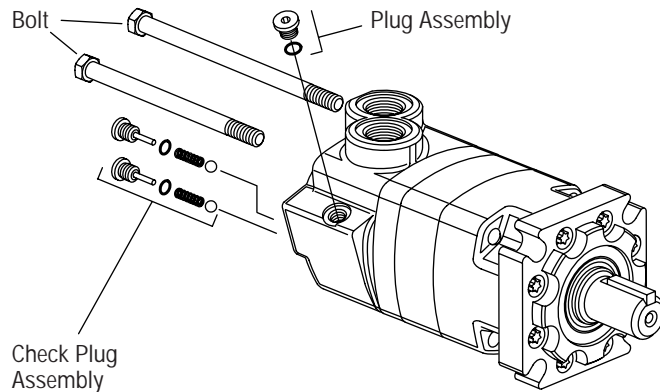

Figure 22

45 Install and finger tighten 2 bolts (or studs for earlier models) opposite alignment studs. Remove alignment studs and install remaining bolts (or studs and 4 nuts for earlier models). Torque bolts (or nuts) to 85 Nm [750 lb-in], in sequence (see Figure 23).

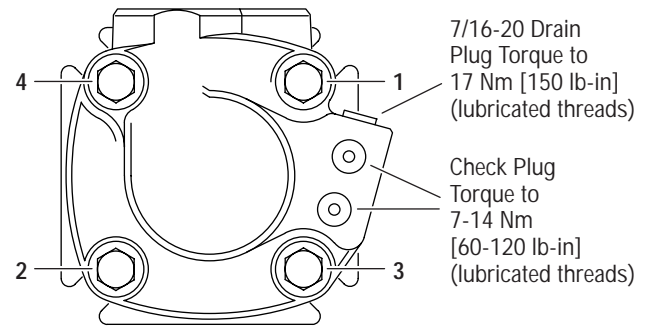

Figure 23

46 Install 2 check plug assemblies (ball, spring, plug with seal). Also install case drain plug with seal, parts shown in Figure 22 (plug torque shown in Figure 24).

Wheel Motors

A different bearing housing is used on wheel motors (see Figure 24). Other than this, the parts are the same as the standard motor and the same disassembly and reassembly procedures apply.

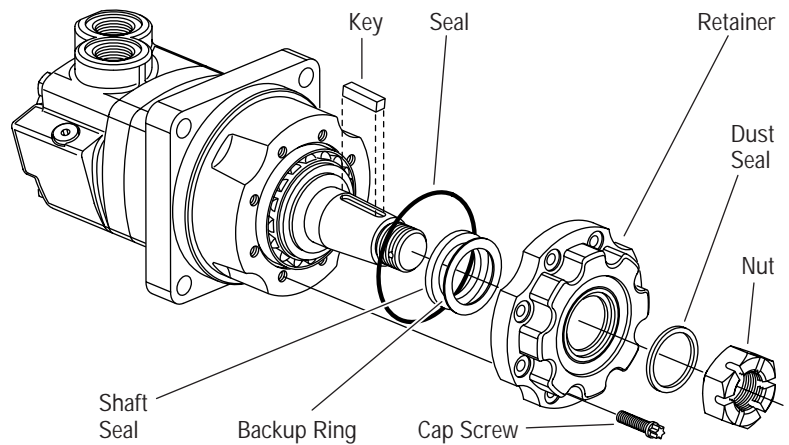

Figure 24

Bearingless Motors

This motor is the same as the standard without the shaft/bearing assembly, bearing housing and retainer. The mounting flange replaces the bearing housing (see Figure 25). Follow same disassembly and reassembly procedures as rear section of standard motor.

Important: Loctite® information for bearingless motor on page 10.

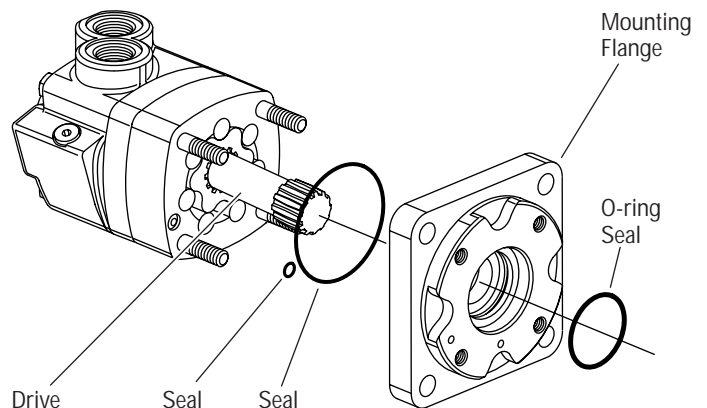

Figure 25

Reassembly

Important: This motor requires Loctite in threaded holes of mounting flange.

Follow these procedures:

Adequate Loctite penetration and sealing depend highly on cleanliness and dryness of threads. Use a non-petroleum base solvent to clean excess oil from threads of flange after disassembly. You may need to use a tap to clean threads of excess old Loctite. After you have fully reassembled the motor, apply 2 to 3 drops of Loctite no. 290 at top of threaded holes (see Figure 26).

Note: Allow Loctite 5 minutes for thread penetration before installing motor on gear case.

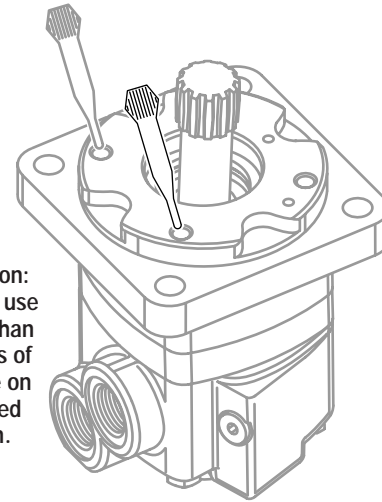

Attention: Do not use more than 3 drops of Loctite on threaded portion.

Figure 26

Motors with Shuttle and, or Seal Guard

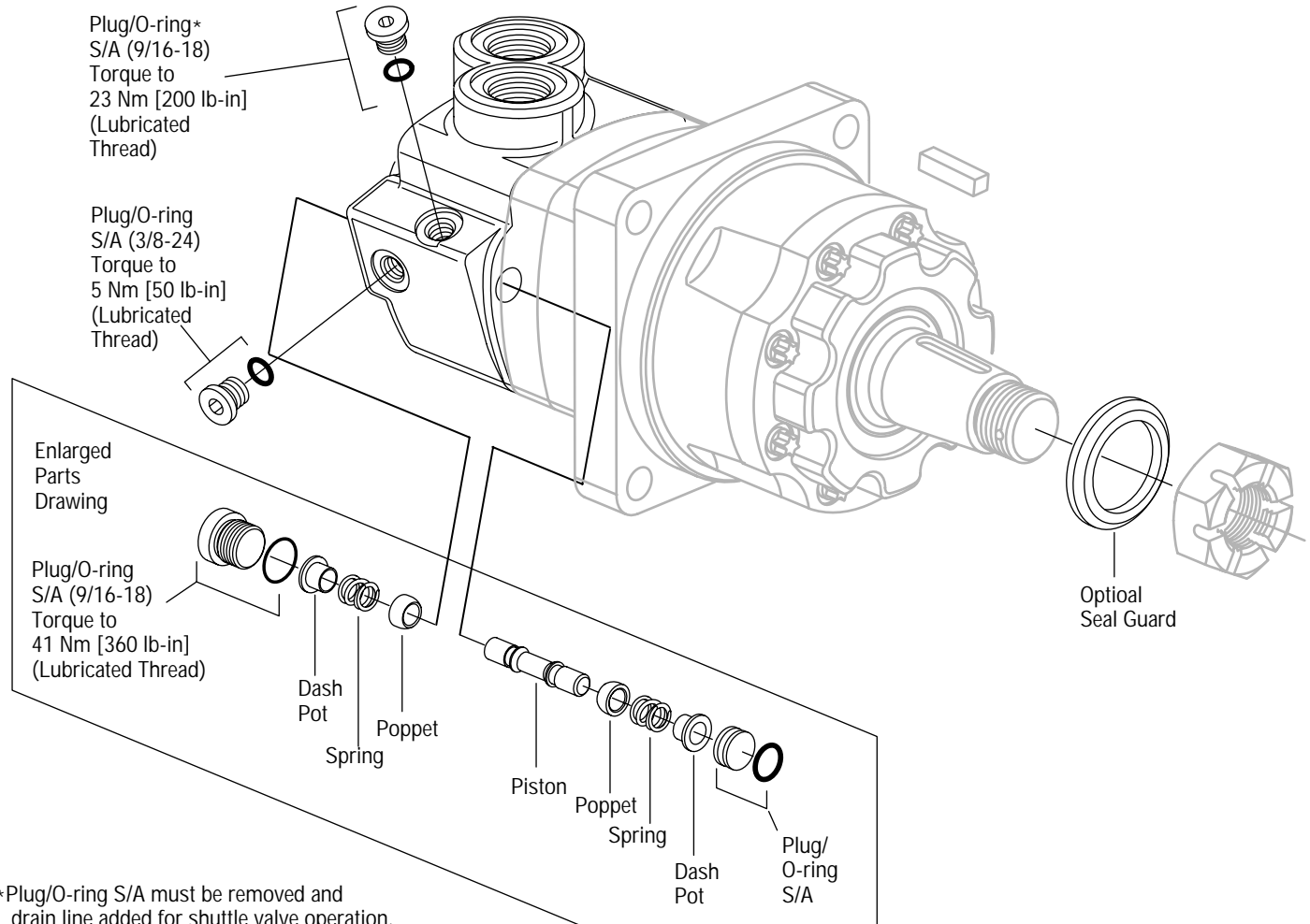

How to Order Replacement Parts

Each Order Must Include the Following:

- 1. Product Number
- 2. Date Code
- 3. Part Name
- 4. Part Number
- 5. Quantity of Parts

For more detailed information contact Eaton Corp. Hydraulics Division 15151 Highway 5 Eden Prairie, MN 55344.

- Specifications and performance data, Catalog No. 11-878.
- Replacement part numbers and kit information — Parts Information No. 6-126.

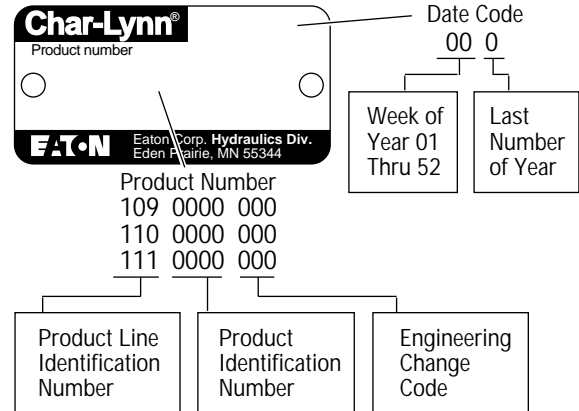

Product Numbers—4000 Series Motors

Use digit prefix —109-, 110-, or 111- plus four digit number from charts for complete product number—Example 111-1057.
Orders will not be accepted without three digit prefix.

Mounting	Shaft	Ports	Displ. cm ³ /r [in ³ /r] Product Number								
			110 [6.7]	130 [7.9]	160 [9.9]	205 [12.5]	245 [15.0]	310 [19.0]	395 [24.0]	495 [30.0]	625 [38.0]
Standard SAE B-Mount	1-1/4 inch Straight	1-1/16 O-ring	109-1100	-1101	-1102	-1103	-1104	-1105	-1106	-1212	-1215
		3/4 inch Split Flange	109-1001	-1054	-1002	-1003	-1055	-1056	-1057	—	—
	1-5/8 Inch Tapered	1-1/16 O-ring	109-1107	-1108	-1109	-1110	-1111	-1112	-1113	—	—
		3/4 inch Split Flange	109-1006	-1058	-1007	-1008	-1059	-1060	-1061	—	—
	1-1/4 Inch 14 T Splined	1-1/16 O-ring	109-1114	-1115	-1116	-1117	-1118	-1119	-1120	—	—
		3/4 inch Split Flange	109-1011	-1062	-1012	-1013	-1063	-1064	-1065	—	—
Standard SAE C-Mount	40 mm Straight	G 3/4 (BSP)	109-1184	-1185	-1227	-1224	-1225	-1189	-1190	—	—
	1-1/2 Inch 17 T Splined	G 3/4 (BSP)	109-1191	-1192	-1193	-1194	-1195	-1196	-1197	—	—
Wheel Motor	1-1/4 inch Straight	1-1/16 O-ring	110-1074	-1075	-1076	-1077	-1078	-1079	-1080	—	-1122
		3/4 inch Split Flange	110-1001	-1040	-1002	-1003	-1041	-1042	-1043	—	—
	40 mm Straight	G 3/4 (BSP)	110-1108	-1109	-1110	-1111	-1112	-1113	-1125	—	—
	1-5/8 Inch Tapered	1-1/16 O-ring	110-1081	-1082	-1083	-1084	-1085	-1086	-1087	1116	-1117
		3/4 inch Split Flange	110-1006	-1044	-1007	-1008	-1045	-1046	-1047	—	—
	1-1/4 Inch 14 T Splined	1-1/16 O-ring	110-1088	-1089	-1090	-1091	-1092	-1093	-1094	—	—
3/4 inch Split Flange		110-1011	-1048	-1012	-1013	-1049	-1050	-1051	—	—	
Bearingless		1-1/16 O-ring	111-1033	-1034	-1035	-1036	-1037	-1038	-1039	-1062	-1063
		3/4 inch Split Flange	111-1044	-1015	-1045	-1046	-1016	-1017	-1018	—	—
		G 3/4 (BSP)	111-1052	-1053	-1054	-1055	-1056	-1057	-1058	—	—

111-1057

Eaton
14615 Lone Oak Road
Eden Prairie, MN 55344
USA
Tel: 952 937-9800
Fax: 952 974-7722
www.hydraulics.eaton.com

Eaton
20 Rosamond Road
Footscray
Victoria 3011
Australia
Tel: (61) 3 9319 8222
Fax: (61) 3 9318 5714

Eaton
46 New Lane, Havant
Hampshire PO9 2NB
England
Tel: (44) 23 92 486 451
Fax: (44) 23 92 487 110



Char-Lynn