

# Char-Lynn®

Disc Valve Motor

July, 1999



## Repair Information

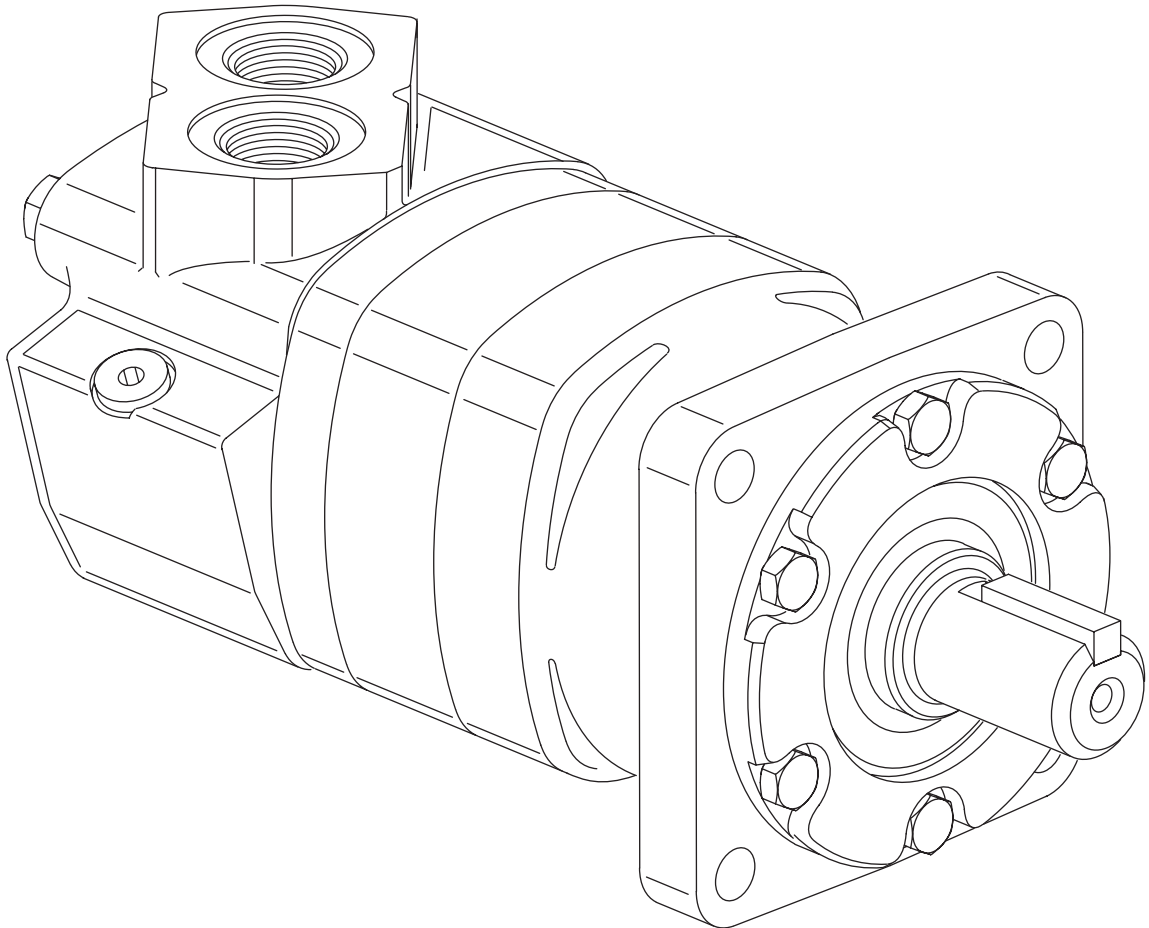

**6000 Series** (includes Big 6)  
**Geroler® Motors**

**-005 and -006**

# Cross Section Drawing

## Char-Lynn® 6000 Series Motor Bearing Package Change

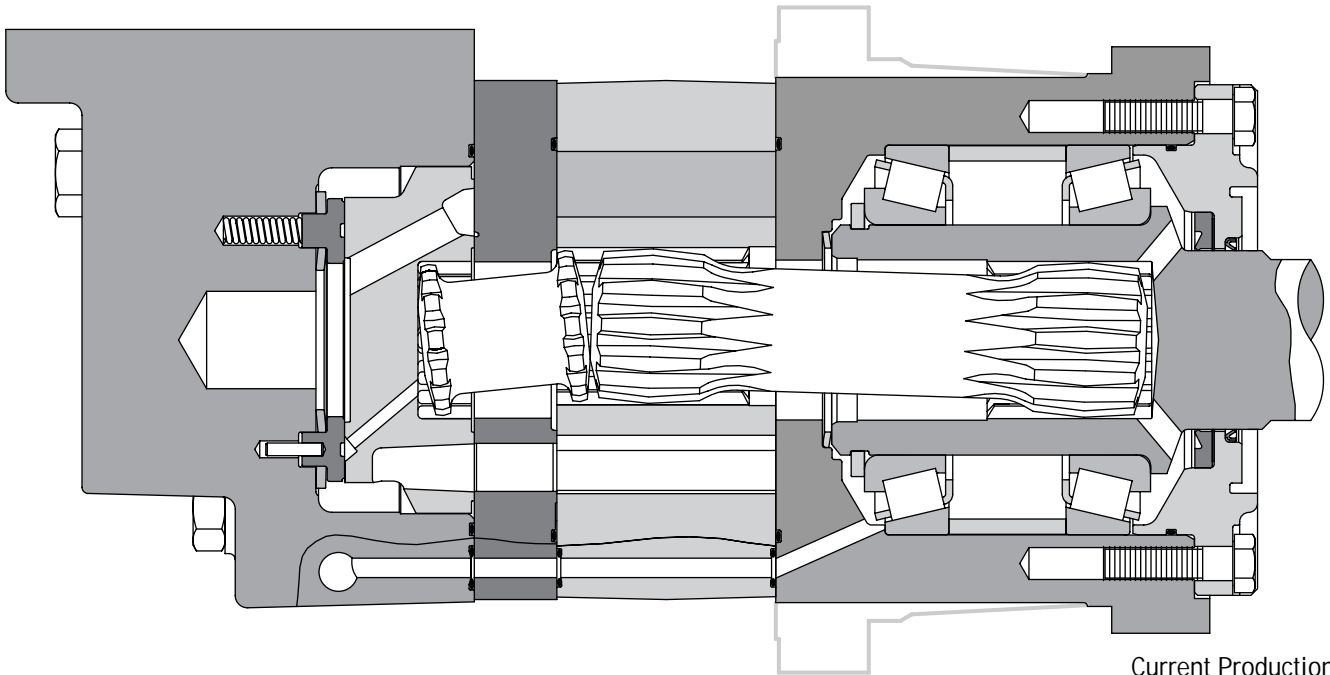

Current Production  
-006 Version

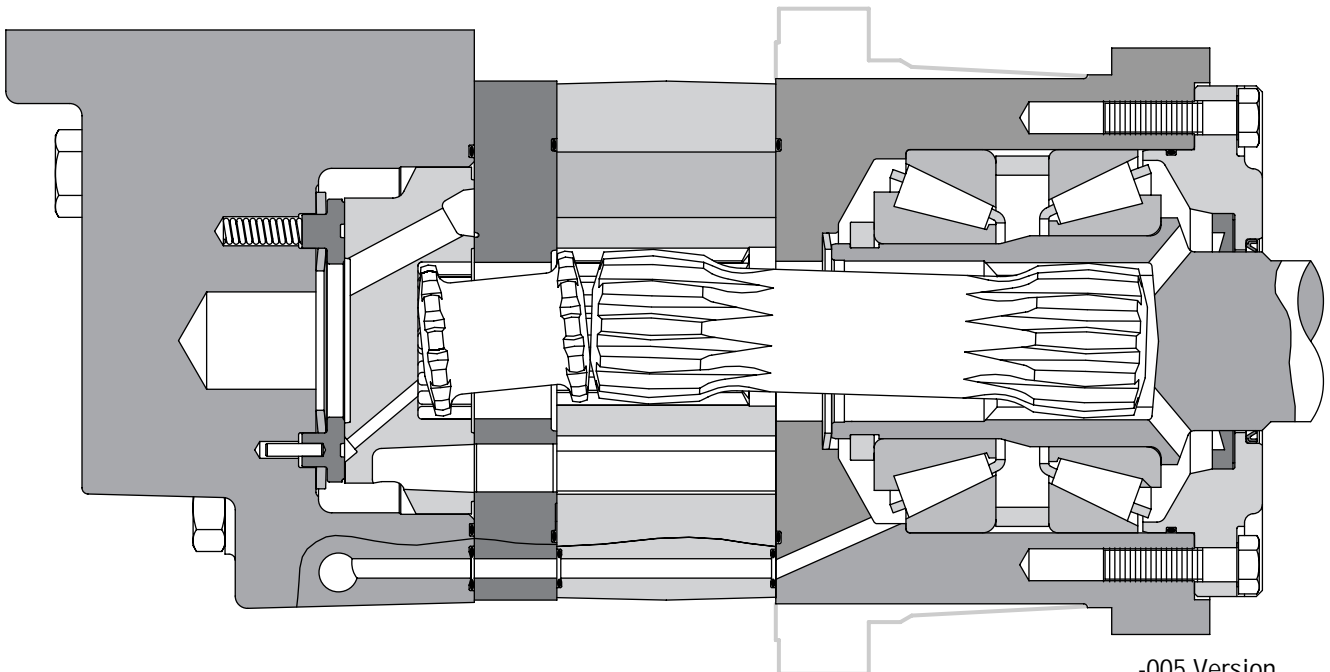

-005 Version

# Parts Drawing

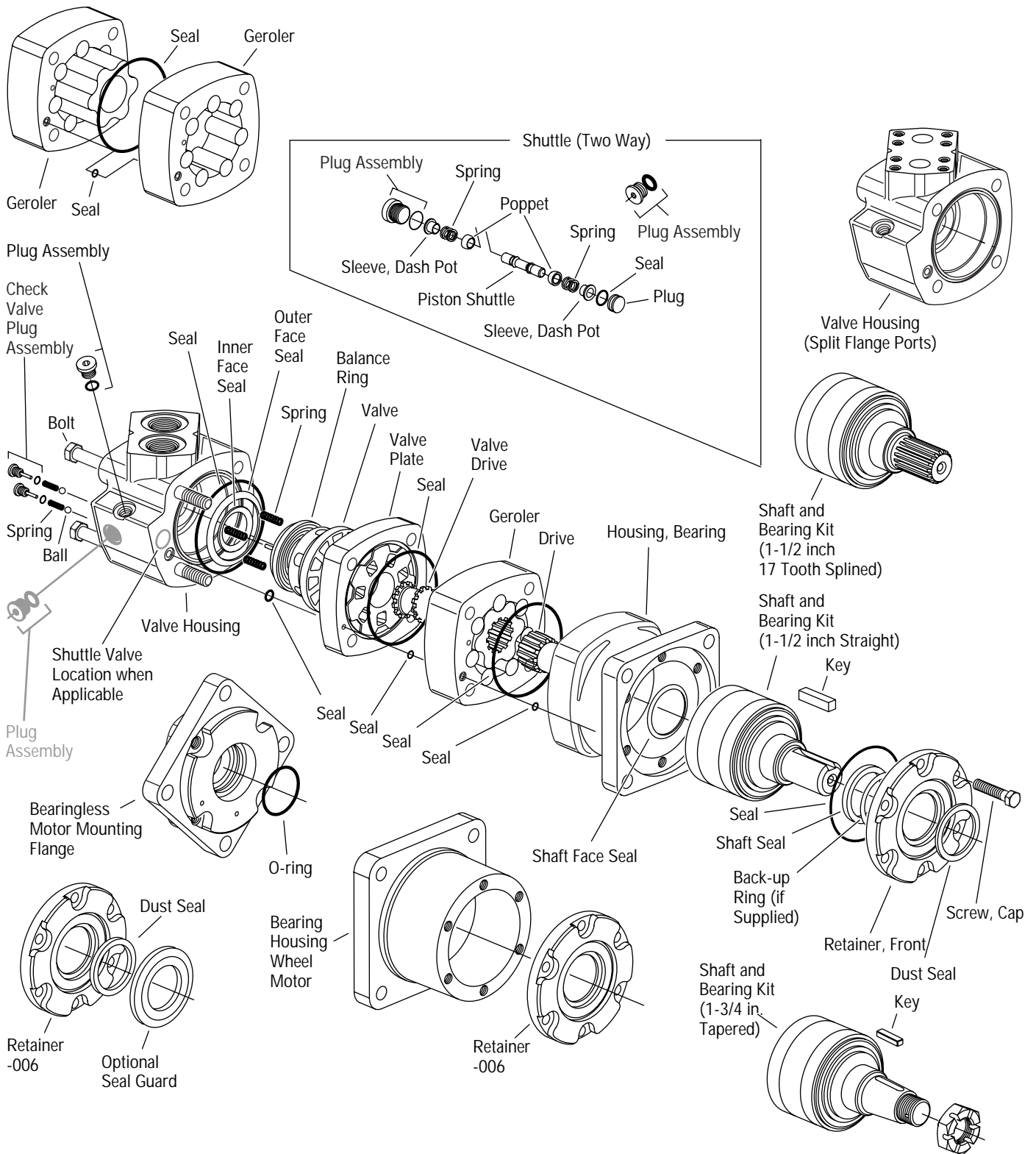

## Parts Drawing — Big 6

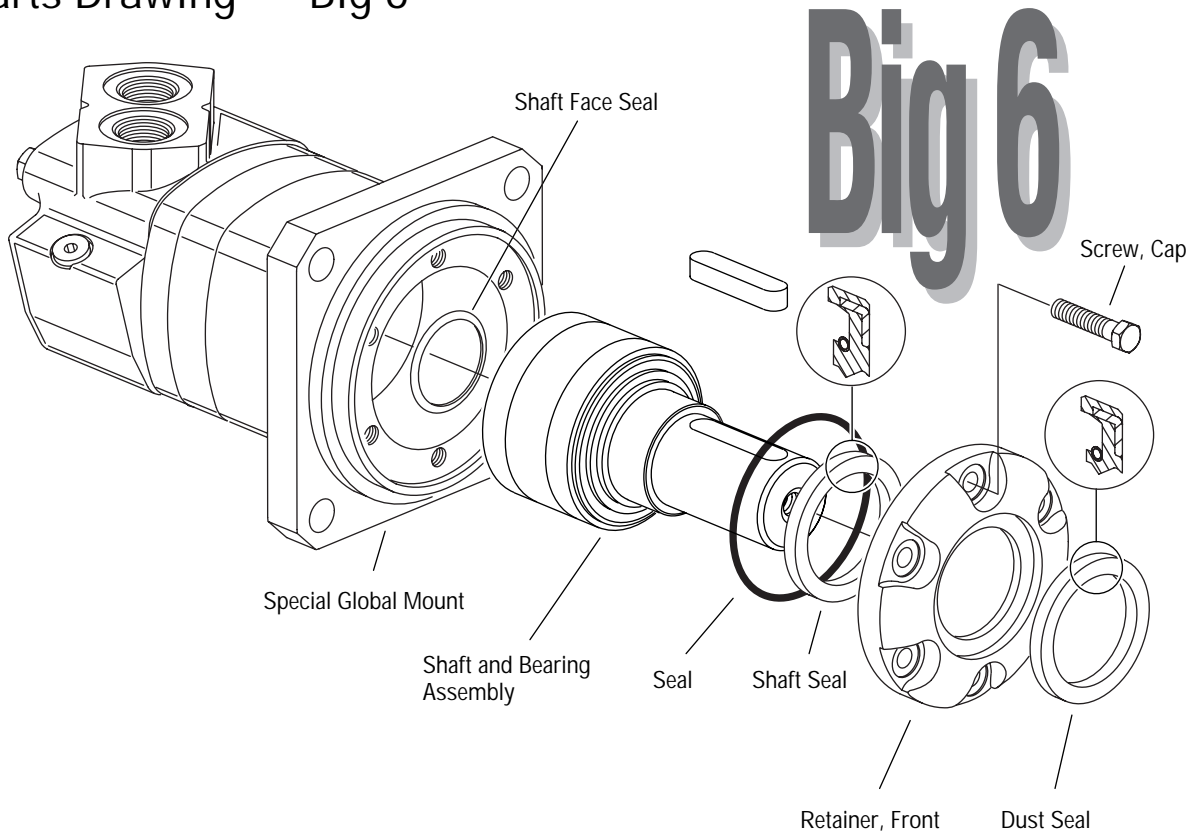

## Tools

Wheel motor and bearingless motor repair information on page 12.  
 Shuttle valve and seal guard repair information on page 13.  
 Seal guard reference on page 13.

### Tools required for disassembly and reassembly

- Torque wrench (90 Nm [800 lb-in] capacity)
- 305 to 406 mm [12 to 16 inch] breaker bar
- 3/4 inch and 1/2 inch sockets
- Small screwdriver (150 to 200 mm [6 to 8 inch] long, 6 mm [1/4 inch] blade)
- 3/16 inch Hex Key
- Hydraulic Press — 1335 N [300 lbf]
- Plastic or rubber hammer
- \* —Bullet (600464) for 1-1/2 inch diameter shafts

\*Available by special order through our service department.

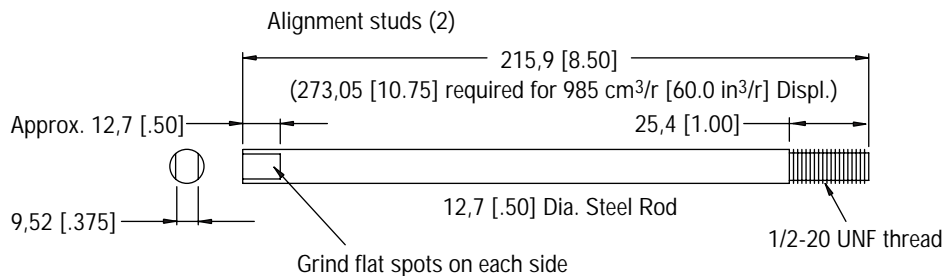

## Disassembly

Cleanliness is extremely important when repairing a hydraulic motor. Work in a clean area. Before disconnecting the lines, clean port area of motor thoroughly. Use a wire brush to remove foreign material and debris from exterior joints of motor. Check shaft and keyway, use 600 grit paper/cloth to remove all nicks, burrs, and sharp edges that might damage the shaft seals when installing retainer on shaft and bearing assembly. Before starting disassembly procedures, drain oil from inside of motor.

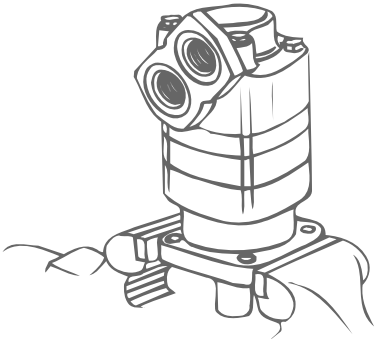

Figure 1

1 Place motor in a vise with output shaft down. Clamp across edge of bearing housing not on housing (see Figure 1). Excessive clamping pressure on housing will cause distortion. When clamping, use some protective device on vise, such as special soft jaws, pieces of hard rubber or board.

Although not all drawings show the motor in a vise, we recommend that you keep the motor in the vise during disassembly. Follow the clamping procedures explained throughout the manual.

2 Remove 4 bolts (or nuts for earlier models) from motor. Remove studs (earlier models) as shown in step 16.

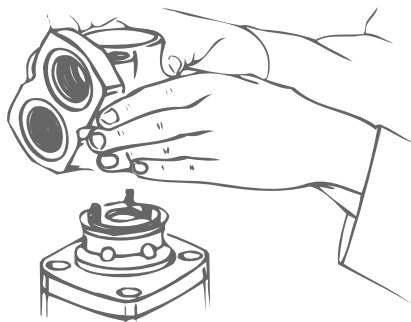

Figure 2

3 Lift valve housing straight up. If done carefully, the springs and balance ring subassembly will remain on valve for easy removal.

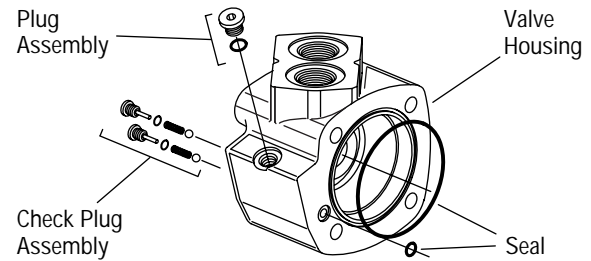

Figure 3

4 Carefully remove the following from the valve housing:

- 1 seal, 92,3 mm [3.63 inch] I.D.
- 1 seal, 7,6 mm [.30 inch] I.D.
- 2 check valve plug assemblies (plug, seal, spring, ball) 1 plug (case drain) with seal.

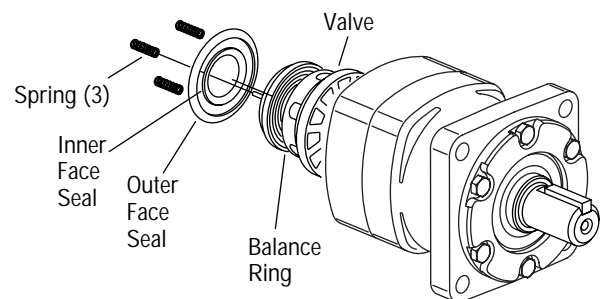

Figure 4

5 Remove 3 balance ring springs.

6 Remove balance ring subassembly.

7 Remove inner and outer face seals from the balance ring.

8 Lift off valve.

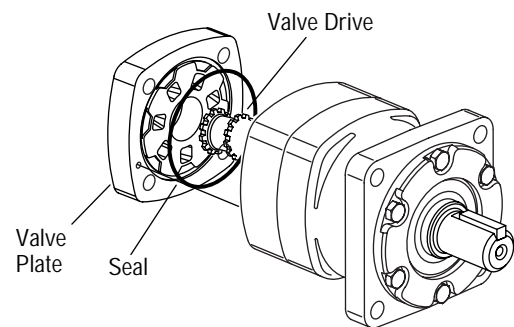

Figure 5

9 Remove valve plate.

10 Remove 95,0 mm [3.74 inch] I.D. seal from valve plate (see Figure 5).

11 Remove valve drive (see Figure 5).

# Disassembly

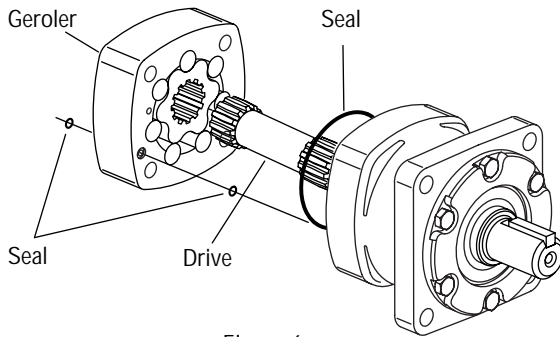

Figure 6

12 Remove Geroler. Retain rollers in outer Geroler ring if they are loose.

13 Remove 2 seals (6,1mm [.24 inch]) from Geroler, 1 seal on each side of Geroler.

14 Remove drive.

15 Remove 95,0 mm [3.74 inch] I.D. seal from bearing housing.

16 Use a stud remover or vise grips to remove studs (earlier models only). Then clamp bearing housing in vise as shown in Figure 7. Loosen 6 bolts. Then remove bolts and retainer. You may have to pry retainer free but do not damage housing or retainer.

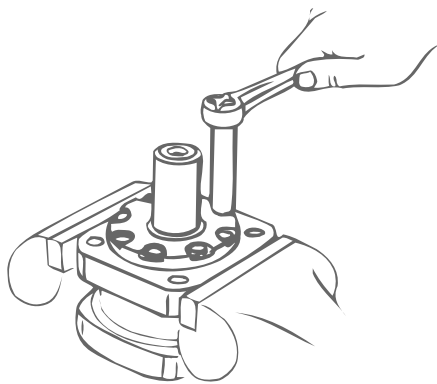

Figure 7

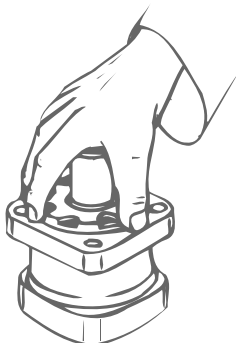

Figure 8

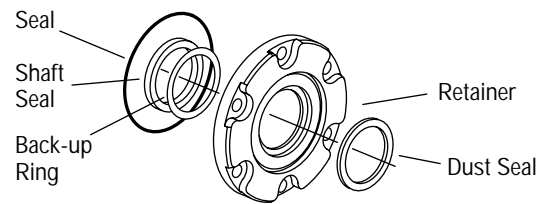

Figure 9

17 Remove 92,3 mm [3.64 inch] I.D. seal, shaft seal and back-up ring (if supplied) from retainer. Use a small screwdriver to remove dust seal. Do not damage bore of retainer.

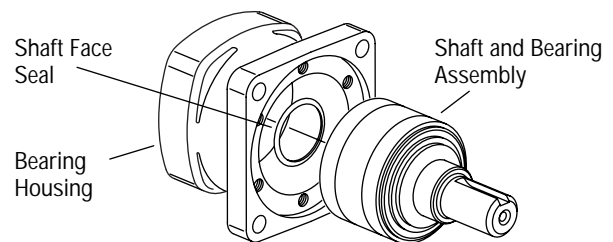

Figure 10

18 Remove shaft and bearing assembly. You may need a press to remove shaft and bearing assembly (see Figure 10).

19 Remove shaft face seal from bore of bearing housing (see Figure 10). Do not damage bore of bearing housing.

Note: Individual parts of the shaft and bearing assembly are not sold separately and must be replaced as a unit.

# Reassembly

Check all mating surfaces. Replace any parts that have scratches or burrs that could cause leakage. Clean all metal parts in clean solvent. Blow dry with air. Do not wipe with cloth or paper towel because lint or other matter could get into the hydraulic system and cause damage. Do not use a coarse grit papers/cloth or try to file or grind motor parts. Check around the keyway and chamfered area of the shaft for burrs, nicks, or sharp edges that can damage the seals when reassembling the retainer.

Note: Lubricate all seals (prior to installation) with petroleum jelly such as Vaseline®. Use new seals when reassembling the motor. Refer to parts list (6-127 6000 Series -005 and 6-159 6000 Series -006) for replacement parts and proper kit number.

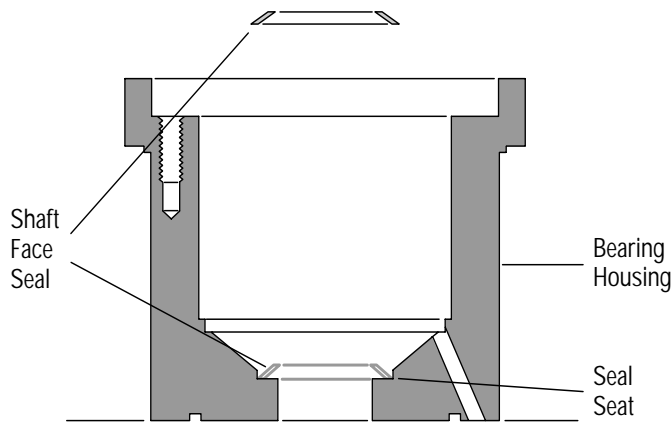

Figure 11

20 Place bearing housing on smooth flat surface with largest open end of housing up.

Apply petroleum jelly to shaft face seal. Install seal in seal seat. Seat seal properly in groove (see Figure 11 and 14). A damaged or improperly installed shaft face seal could cause internal lubrication loss and subsequent parts wear.

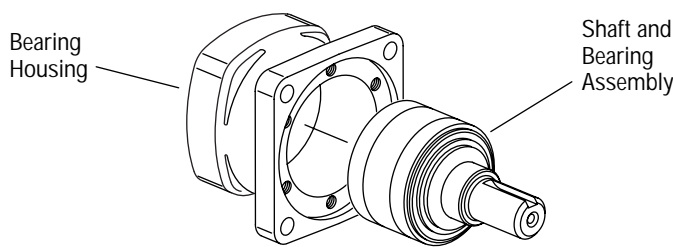

Figure 12

21 Install shaft and bearing assembly in bearing housing (see Figure 12). Do not damage seal in bore of housing. You may need a press to install shaft and bearing assembly.

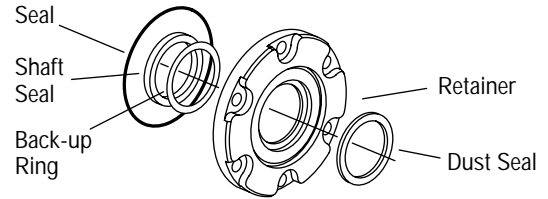

Figure 13

22 Use a small press, if available, to install dust seal in retainer. Metal side of dust seal must face toward retainer as shown in Figure 14. If a press isn't available, use a plastic or rubber hammer to tap dust seal in place.

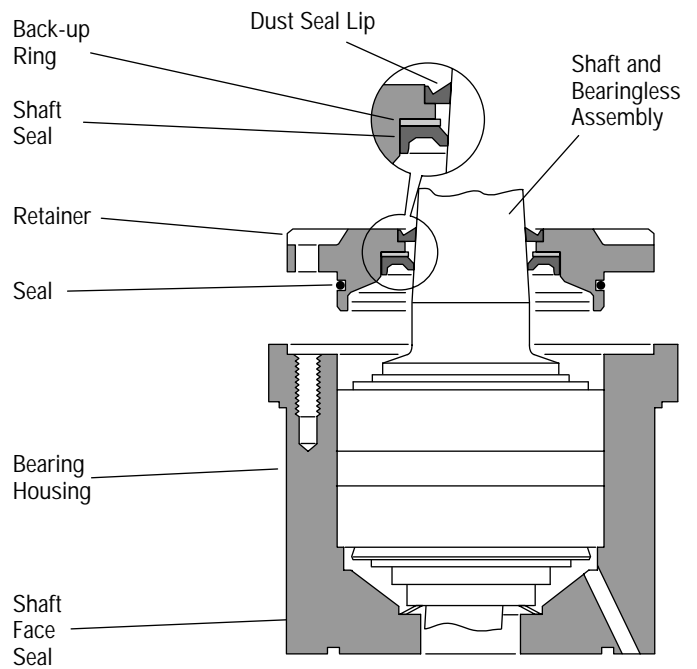

Figure 14

23 Install 92,3 [3.64] I.D. seal, back-up ring and shaft seal in retainer. Flat or smooth side of shaft seal must face toward retainer as shown in Figure 14. Apply petroleum jelly to inside diameter of shaft seal (after installing seal).

24 Before installing retainer, place a protective sleeve of bullet (see note below) over shaft. Grease inside diameter of dust and shaft seals. To prevent damage to seals, install retainer over shaft with a twisting motion. Do not cut or distort shaft seal. Damage to shaft seal will cause external leakage.

Note: Bullet 600464 for 1-1/2 inch diameter shafts available—by special order through our service department.

# Reassembly

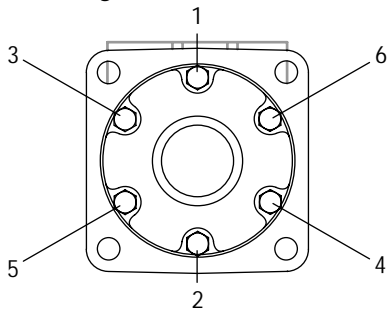

Figure 15

25 Lubricate threads of 6 bolts with a film of light oil. Install and finger tighten all 6 bolts. Torque bolts to 6 Nm [50 lb-in] in sequence (see Figure 15). Then final torque to 34 Nm [300 lb-in], in sequence.

Note: Full torque 34 Nm [300 lb-in] on one bolt at a time can damage bolt or retainer.

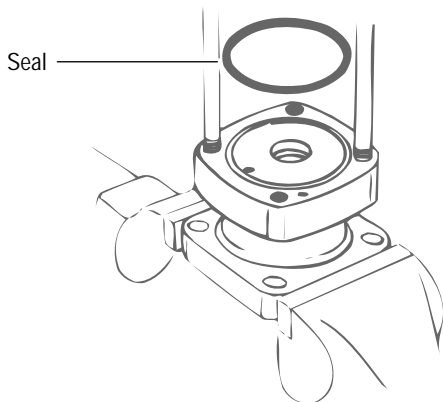

Figure 16

27 Reposition motor in vise with output shaft down. Clamp across edges of retainer as shown in Figure 16.

28 Pour a small amount of light oil inside the output shaft.

29 Install 2 studs (earlier models), diagonally opposed, in bolt holes of bearing housing (see Figure 16). If you replace studs with bolts, use 2 studs for alignment purposes when stacking parts.

30 Apply a light film of petroleum jelly on 95,0 mm [3.74 inch] I.D. seal. Install seal in bearing housing (see Figure 16).

31 Install drive in output shaft (insert longer splined end of drive first), (see parts drawing on page 3).

32 Apply petroleum jelly on 2 seals, 6,1 mm [.24 inch] I.D. Install seals (1 on each side of Geroler) in case drain grooves of Geroler.

Note: Installation at this point involves 3 steps in timing the motor. Timing determines the direction of rotation of the output shaft.

Timing parts include:

1. Geroler
2. Valve drive
3. Valve Plate
4. Valve

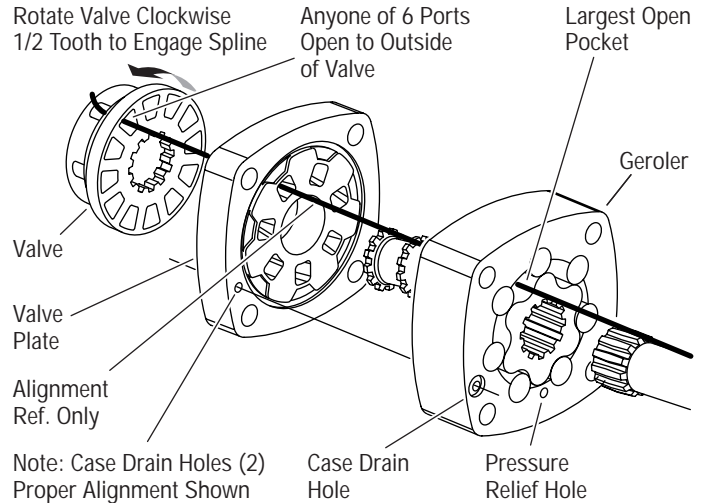

Figure 17 Timing Alignment

Timing Step No. 1 — Locate largest open pocket in Geroler. Then mark location of pocket on outside edge of Geroler (see Figure 17).

33 Align case drain hole and pressure relief hole in Geroler with case drain hole and pressure relief hole in bearing housing. Install Geroler on bearing housing (see Figure 17). Retain rollers in outer Geroler ring if they are loose.

34 Install valve drive in Geroler.

35 Apply a light film of petroleum jelly on 95,0 mm [3.74 inch] I.D. seal. Install seal in valve plate.

36 Align case drain hole in valve plate with case drain hole in Geroler. Install valve plate (seal side toward Geroler) on Geroler as shown in Figure 17.

Timing Step No. 2 — Locate slot opening in valve plate which is in line with largest open pocket of Geroler (see Figure 17).

37 Use the following procedure for installing the valve on the valve plate.

Timing Step No. 3 — Locate any one of the side openings of the valve that goes through to the face of the valve. Line up this side opening in the valve with open slot of valve plate that is in line with largest open pocket of Geroler. Rotate valve clockwise (1/2 spline tooth) to engage valve with the valve drive spline, alignment reference shown in Figure 17 (above). This procedure provides standard timing when pressurized as shown in Figure 18 (below) .

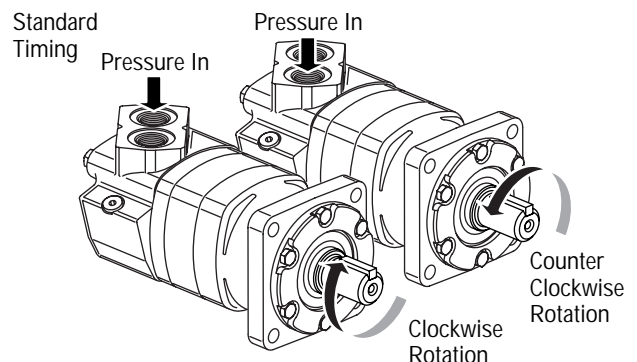

Figure 18



# Reassembly

38 Apply clean grease on 3 balance ring assembly springs. Install springs in 3 holes located inside bore face of valve housing (see Fig. 19).

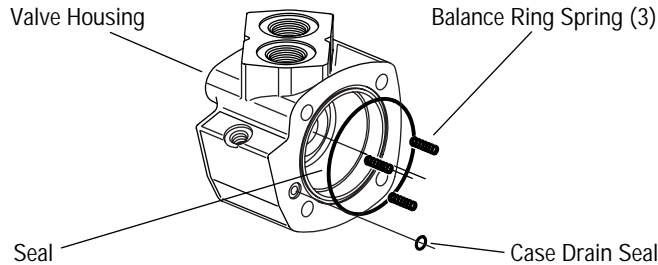

Figure 19

39 Apply a light film of petroleum jelly on 7,6 mm [.30 inch] I.D. seal. Install seal in case drain groove of valve housing.

40 Apply a light film of petroleum jelly on 92,3 mm [3.63 inch] I.D. seal. Install seal in outside seal groove of valve housing.

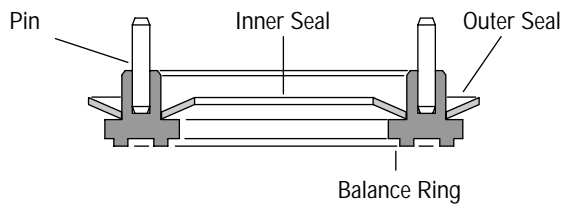

Figure 20

41 Apply petroleum jelly on inner and outer face seals. Install seals on balance ring as shown in Figure 20.

**Important:** Install face seals in the positions shown in Figure 20 or the motor will not operate properly. Do not force or bend these face seals. Any damage to these seals will affect the operation of the motor.

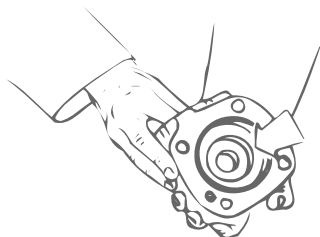

Figure 21

42 Align balance ring assembly pins with 2 holes in valve housing (see Figure 21). Install balancing ring subassembly in valve housing.

43 Insert your finger through port of housing. Apply pressure to side of balance ring assembly. Hold ring in position until valve housing is in place (see Figure 21). Align case drain hole in housing with case drain hole in valve plate. Install valve housing against valve plate (see Figure 22).

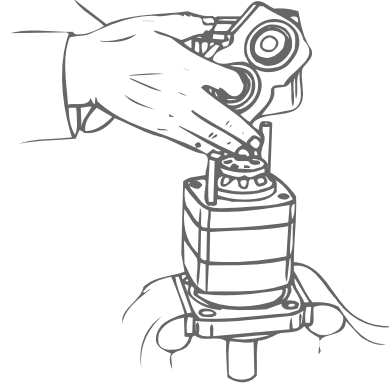

Figure 22

**Note:** After installing valve housing on valve plate, check between body parts of motor for unseated seals.

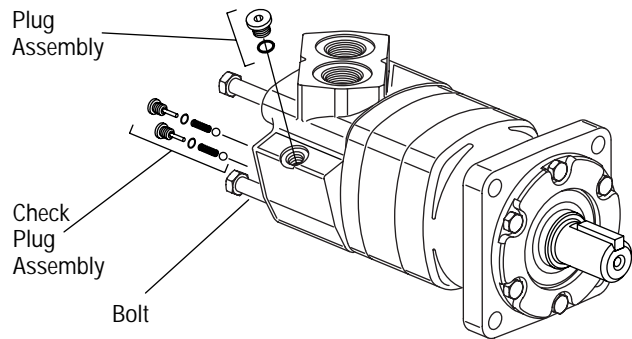

Figure 23

44 Install and finger tighten 2 bolts (or studs for earlier models) opposite alignment studs. Remove alignment studs and install remaining bolts (or studs and 4 nuts for earlier models). Torque bolts (or nuts) to 98 Nm [864 lb-in/ 72 lb-ft], in sequence (see Figure 24).

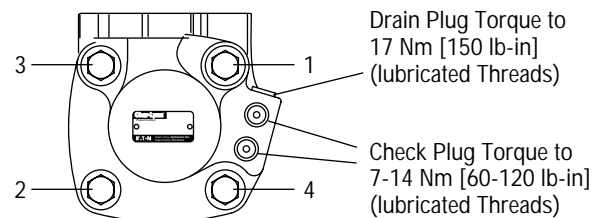

Figure 24

45 Install 2 check plug assemblies (ball, spring, plug with seal). Also install case drain plug with seal, parts shown in Figure 23 and plug torque shown in Figure 24.

## Wheel Motors

A different bearing housing is used on wheel motors (see Figure 25). Other than this, the parts are the same as the standard motor and the same disassembly and reassembly procedures apply.

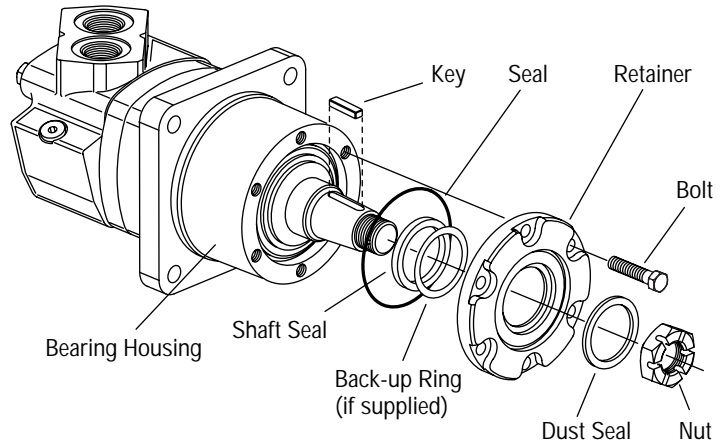

Figure 25

## Bearingless Motors

This motor is the same as the standard without the shaft/bearing assembly, bearing housing and retainer. The mounting flange replaces the bearing housing (see Figure 26). Follow same disassembly and reassembly procedures as rear section of standard motor.

Important: Loctite® information for bearingless motor below.

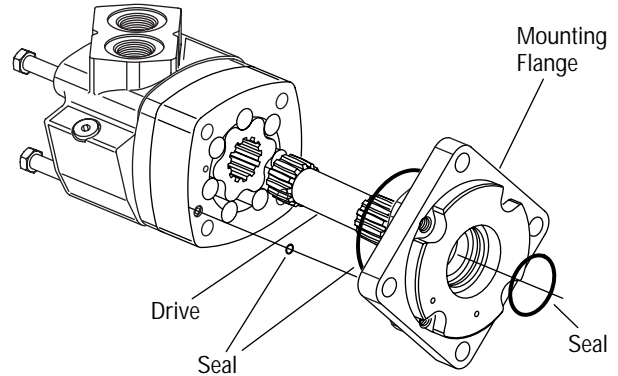

Figure 26

Important: This motor requires Loctite in threaded holes of mounting flange.

Follow these procedures:

Adequate Loctite penetration and sealing depend highly on cleanliness and dryness of threads. Use a non-petroleum base solvent to clean excess oil from threads of flange after disassembly. You may need to use a tap to clean threads of excess old Loctite. Then, after you have fully reassembled the motor, apply 2 to 3 drops of Loctite no. 290 at top of threaded holes (see Figure 27).

Note: Allow Loctite 5 minutes for thread penetration before installing motor on gear case.

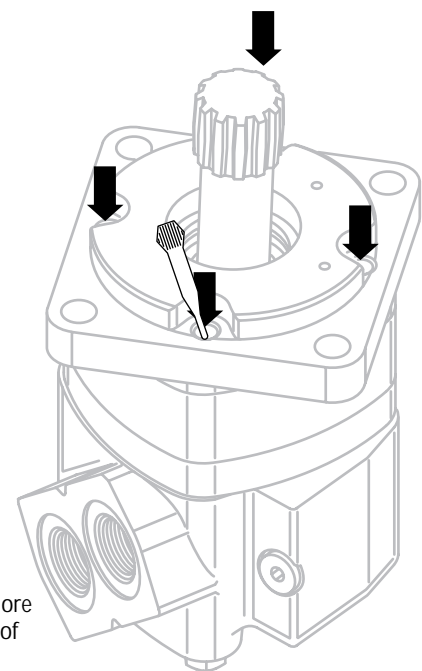

Attention:  
Do not use more than 3 drops of Loctite on threaded portion.

Figure 27

# Motors with Shuttle and, or Seal Guard

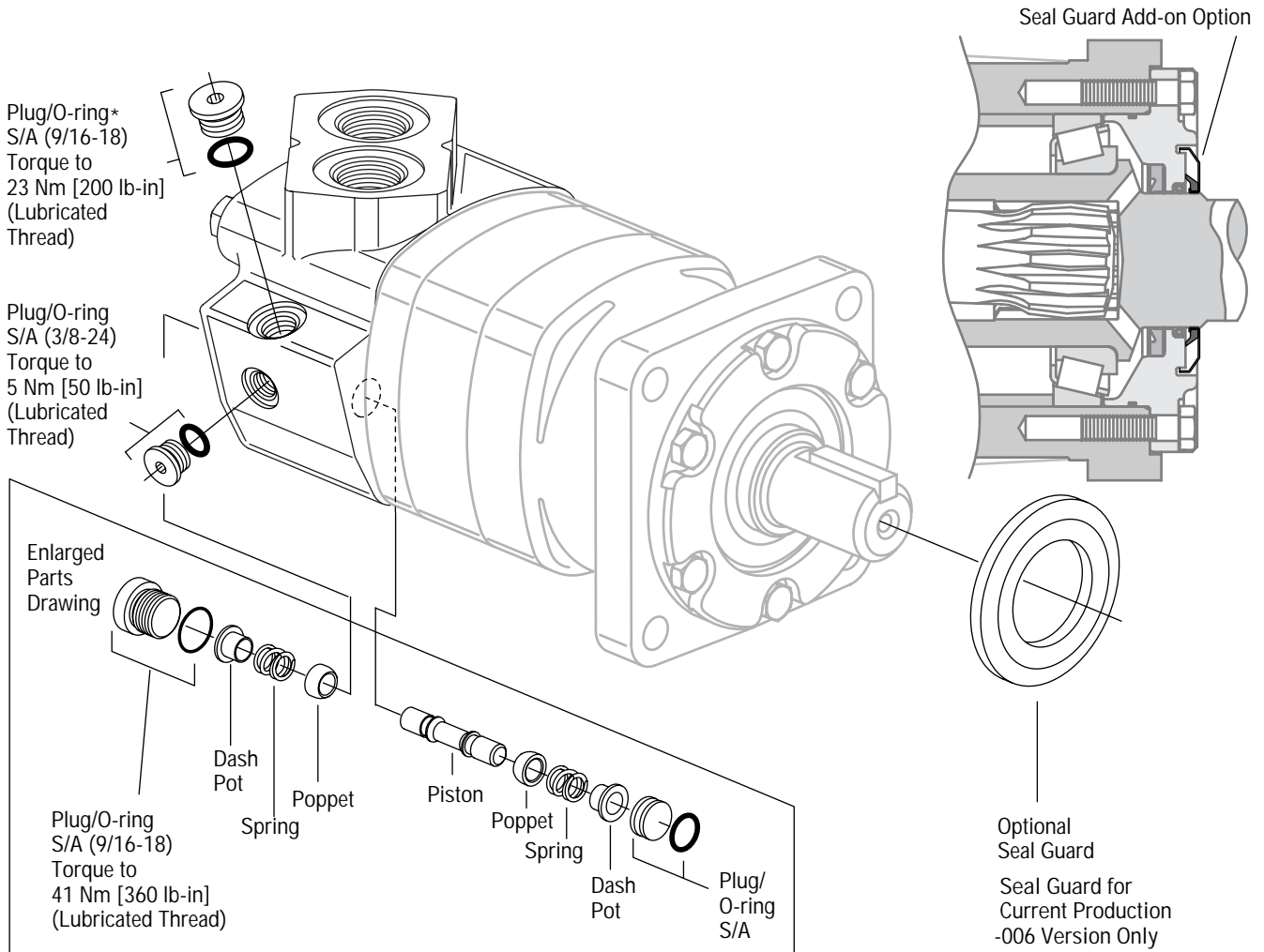

\*Plug/O-ring S/A must be removed and drain line added for shuttle valve operation.

## How to Order Replacement Parts

Each Order Must Include the Following:

1. Product Number
2. Date Code
3. Part Name
4. Part Number
5. Quantity of Parts

For More Detailed Information Contact Eaton Corp. Hydraulics Division 15151 Highway 5 Eden Prairie, MN 55344.

- Specifications and performance data, Catalog No. 11-878
- Replacement parts numbers and kit information. —Parts information 6-127 (for 6000 Series -005 and -006)

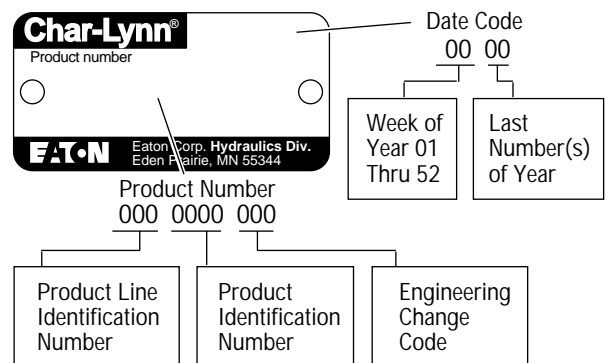

## Disc Valve Motors

# 6000 Series Motors

### Product Numbers—6000 Series Motors

Use digit prefix —**112-**, **113-**, or **114-** plus four digit number from charts for complete product number—Example **114-1047**.

Mounting	Shaft	Ports	Displacement cm <sup>3</sup> /r [ in <sup>3</sup> /r ] and Product Number						
			195 [11.9]	245 [ 15.0]	310 [19.0]	390 [23.9]	490 [30.0]	625 [38.0]	985 [60.0]
Standard	1-1/2 inch Straight	1-5/16 O-ring	<b>112-1064</b>	-1065	-1066	-1067	-1068	-1107	-1069
	40 mm Straight	G 1 (BSP)	<b>112-1094</b>	-1095	-1096	-1097	-1098	—	-1099
	1-1/2 Inch 17 T Splined	1-5/16 O-ring	<b>112-1058</b>	-1059	-1060	-1061	-1062	-1109	-1063
		G 1 (BSP)	<b>112-1088</b>	-1089	-1090	-1091	-1092	—	-1093
Wheel Motor	40 mm Straight	G 1 (BSP)	<b>113-1082</b>	-1083	-1084	-1085	-1086	-1100	-1087
	1-3/4 Inch Tapered	1-5/16 O-ring	<b>113-1070</b>	-1071	-1072	-1073	-1074	-1093	-1075
Bearingless		1-5/16 O-ring	<b>114-1031</b>	-1032	-1033	-1034	-1035	-1055	-1036
		G 1 (BSP)	<b>114-1043</b>	-1044	-1045	-1046	-1047	—	-1048

114-1047

### Product Numbers – 6000 Series (Big 6)

Mounting Type - Standard (Code H), 4 Bolt:

- **160,0 [6.30] Pilot Dia.**
- **18,01 [.709] Dia. Mounting Holes**
- **200,0 [7.87] Dia. Bolt Circle**

Output Shaft - Straight (Code 21)

Ports - G1 (BSP) Staggered G 1/4 Case Drain (Code C)

Paint - Low Gloss Black

Use digit prefix —**112-** plus four digit number from charts for complete product number—Example **112-1215**.

**Orders will not be accepted without three digit prefix.**

112-1215

Mounting	Shaft	Ports	Displacement cm <sup>3</sup> /r [ in <sup>3</sup> /r ] and Product Number						
			310 [19.0]	390 [23.9]	490 [30.0]	625 [38.0]	737 [45.0]	800 [49.0]	985 [60.0]
Standard	50 mm Straight	G 1 (BSP)	112-1217	-1218	-1215	-1216	-1247	-1219	-1220

# Big 6

**Eaton**  
Fluid Power Group  
Hydraulics Business USA  
14615 Lone Oak Road  
Eden Prairie, MN 55344  
USA  
Tel: 952-937-9800  
Fax: 952-294-7722  
[www.eaton.com/hydraulics](http://www.eaton.com/hydraulics)

**Eaton**  
Fluid Power Group  
Hydraulics Business Europe  
Route de la Longeraie 7  
1110 Morges  
Switzerland  
Tel: +41 (0) 21 811 4600  
Fax: +41 (0) 21 811 4601

**Eaton**  
Fluid Power Group  
Hydraulics Business Asia Pacific  
11th Floor Hong Kong New World Tower  
300 Huaihai Zhong Road  
Shanghai 200021  
China  
Tel: 86-21-6387-9988  
Fax: 86-21-6335-3912